



## Product Change Notice (PCN)

<b>Manufacturer:</b>	<b>For queries:</b>
RAYLASE GmbH Argelsrieder Feld 2+4 82234 Wessling Germany <a href="mailto:info@raylase.de">info@raylase.de</a> <a href="http://www.raylase.de">www.raylase.de</a>	Your customer number: Your contact person: Tel.: +49 8153 9999 699 E-mail: PDN@raylase.de  Date of publication: 30/04/2021 PCN ID/version: 202101-01

### Reason for change:

Due to technical improvements regarding the applicability of the product, another thread was added to the opto-mechanical interface of the deflection unit for camera observation (see drawing page 2).  
This does not result in any change or impairment of the previous functionality.

Discontinued product series and products			Replacement	
Article no.	Description		Article no.	Description
TURBOSCAN II			Successor product	
M000008231	TS-II-30 [C] V2	SI-[NL]-RA-D1	No change to article name and article number	

### Timeline for change:

Implementation immediately on April 30, 2021.  
All orders received after April 30th, 2021 will be delivered with the new revision status.

Thank you in advance for taking this product change into account. If you have any questions, please do not hesitate to contact us.

Kind regards

Wolfgang Lehmann  
Head of Product Management  
RAYLASE GmbH

CR-0326 | Product Change of M000008231 TS-II-30 [C] V2 SI-[NL]-RA-D1  
 Component: M000008210 Mounting Plate 046, drawing M032582-02

Previous Status Rev 01

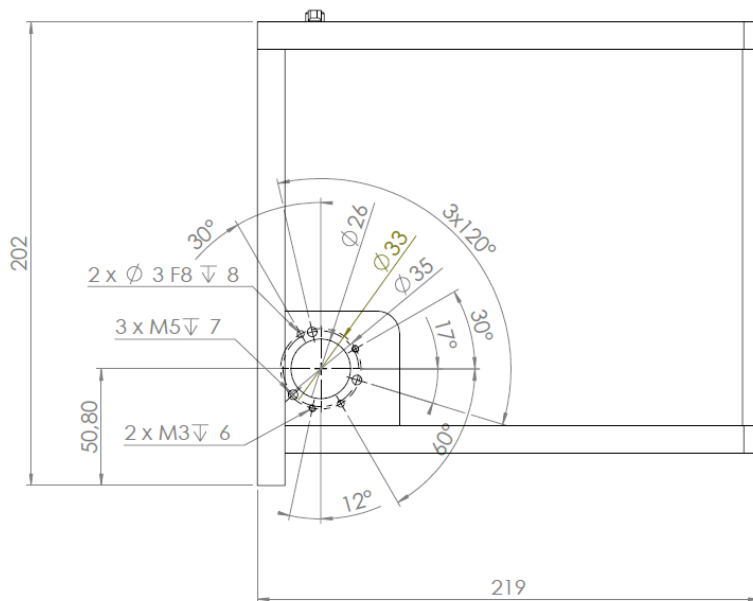

New Status Rev 02

A thread M3x6 has been added (see red circles)

