

# AM-MODULE III

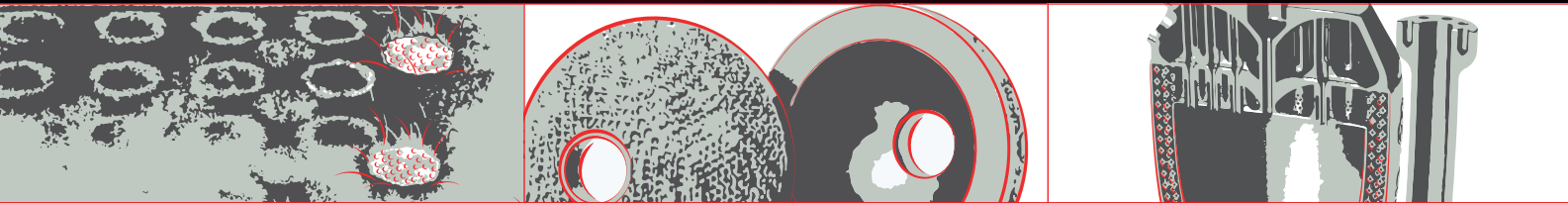

ADDITIVE MANUFACTURING – RAPID PROTOTYPING – ADDITIVE PRODUCTION



## HIGH PERFORMANCE FOR AM-PRODUCTION

The AM-MODULE III is an **integrated pre-focusing beam deflection unit** specifically for use in additive manufacturing. Thanks to its dust-tight housing and integrated collimating optics, the AM-MODULE III is the ideal deflection unit for use in industrial production.

In additive manufacturing, efficiency of the production line and AM equipment is the key to success. The goal is to keep the costs per part as low as possible and thus remain competitive with existing manufacturing methods. To achieve this, all aspects of the AM machine are trimmed for **high exposure speeds and high reliability** at the same time. After all, when a machine is down, it doesn't earn money.

This is precisely what we kept in mind when designing the AM-MODULE III. A dust-proof housing and manufacturing in an ISO Class 7 clean room **allows the use of more powerful lasers**. In addition, the spot can be adjusted dynamically in diameter using the **integrated zoom function** without losing image quality. As a result, fine structures are exposed with high resolution and large areas can be filled with an enlarged spot diameter at constant power density and scanning speed. This makes additive manufacturing a real competitor to existing manufacturing methods and it can be used for a wide range of applications.

Combined with the integrated design and the resulting high reliability in the **industrial production environment**, this increase in performance enables AM users to take the next step: The step from rapid prototyping to additive production!

[www.raylase.com](http://www.raylase.com)



Highest dynamics



Dynamic Zoom function



Optimized for industrial production

## OPTIMIZED FOR INDUSTRIAL AM PRODUCTION

The AM-MODULE III is designed for additive production. This means reliability and process safety were basic ideas in the development of the system. **Precise and pre-aligned integrated collimation and scanner optics** allow to use **lasers with best beam quality**. The additional zoom function ensures that the **focus shape is always maintained, even when working with dynamically enlarged spot diameters**. And it can also dynamically compensate for possible variations in energy density in the scan field.

The philosophy of production and reliability is reflected in various aspects: for example, the digital scanners allow a convenient **read-back of position data**, which can then be easily merged with measurement data from the **coaxial process light or camera port**. This enables precise process monitoring and control. In addition, the **housing is also designed for productivity**: It enables low-maintenance operation, thanks to its optimized dust-proof housing design and innovative RAYVOLUTION DRIVE technology. And with its scalable design, multiple lasers can work simultaneously on one component, **enabling even the shortest production cycle times** in demanding production lines.

Precisely this combination makes the AM-MODULE III the optimal solution for your AM production. See for yourself:

### Highly dynamic z-focusing with RAYVOLUTION DRIVE technology

Ensures stable z-position and penetration depth independent of machining speed

### Integrated fiber adapter and collimator for all common fiber lasers

Ensures optimal beam configuration and simplifies integration into a production line

### Digital control with RL3-100 protocol

Enables high-precision control and additionally feedback of position and status signals for process monitoring and optimization

### OPTIONAL: Focus tracking camera port with RAYSPECTOR.

Enables an "on-axis" vision solution with sharp imaging independent of deflection angle and z position

### Dust-proof housing (IP64) and clean room production

Allows the use of high laser powers up to 2 kW single mode\* even under harsh production conditions  
\* up to 4 kW for multi mode laser

### Integrated process light output without chromatic aberrations

Offers a wide range of possibilities for "on-axis" process monitoring and process control such as pyrometer

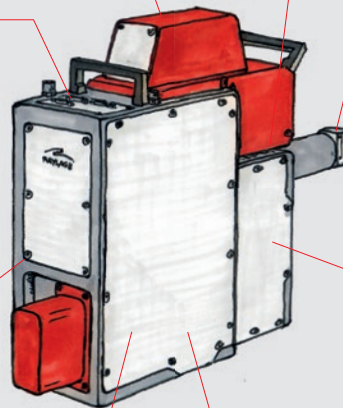

### Dynamic zoom functionality

Increases the spot diameter in the focal position by up to a factor of 2, simultaneously allowing fine structures and fast filling in bulk material. This saves valuable process time and increases productivity

### "Scalable design" with 100% overlap of adjacent build areas

Allows scaling of production by simultaneously machining a workpiece with multiple lasers and deflection units

## HIGHER PRODUCTIVITY THROUGH DYNAMIC ZOOM FUNCTION

The right brush size for every application. This is made possible by the **highly dynamic zoom function** of the AM-MODULE III. One of the challenges in additive manufacturing is to keep the exposure time per plane as short as possible in order to produce profitably. For this reason, the laser is regularly defocused to **fill large areas**. This allows more area to be filled with each pass, saving the number of hatches and thus processing time.

However, like a brush that is pressed on too hard, the shape of the laser spots is poorly defined outside the focus position. **For special beam profiles such as tophat or ring mode**, this becomes particularly obvious, because here the special beam shape is lost even with slight defocusing, and the advantages of a higher exposure speed without balling effects and spattering are lost. Therefore, defocus can only be used to fill areas to a limited extent.

In contrast, the zoom function of the AM-MODULE III allows **dynamic adjustment of the focus diameter by up to 2x** and at the same time ensures that it is still possible to work in focus with an **undisturbed beam profile** even with an enlarged spot diameter. This way, the **higher exposure speeds** of using a ring or tophat profile can be effectively combined with the time savings of a **larger spot diameter**. And the AM-MODULE III thus makes a decisive contribution to ensuring that the **high build rates** that are so important for additive production can also be implemented in the machine.

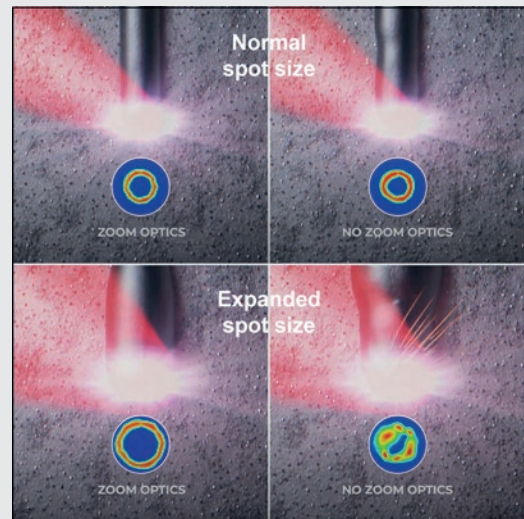

Comparison of zoom function vs. defocus

## FASTER EXPOSURE SPEED THANKS TO RAYVOLUTION DRIVE

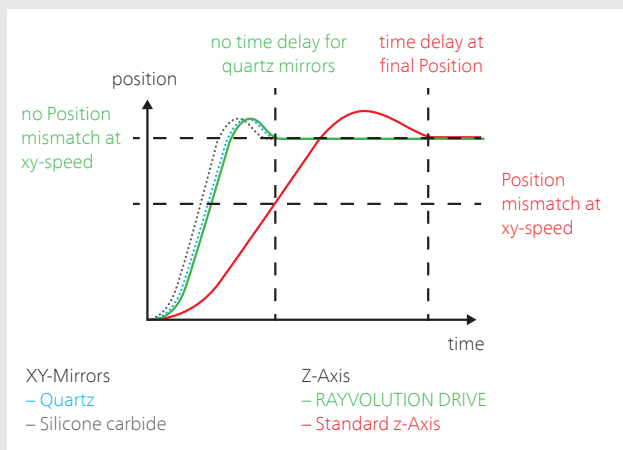

With RAYVOLUTION DRIVE, the z-axis follows the xy-movements of deflection units with quartz mirrors without delay. Quite in contrast to a standard z-axis, which shows significantly slower dynamics. When using highly dynamic silicon carbide mirrors, a small difference in dynamics still remains visible, which can be compensated using the function Tracking Error Compensation of the SP-ICE-3 Control Card.

Pre-focusing beam deflection units such as the AM-MODULE III use a combination of moving and fixed lenses in front of the scan mirrors to focus the laser. To keep the **focus in a constant z-plane**, the lens is tracked and the focal length adjusted with each movement. But at higher dynamics, many focus shifters can no longer follow the movement of the XY mirrors, which can lead to non-uniform power input in the powder.

To take advantage of a pre-focusing system and at the same time use the **full dynamics** of the XY deflection unit, the RAYVOLUTION DRIVE (RD) technology was developed. It is based on the moving coil principle to shift the lenses, which allows **very fast movements of the lens**. This allows to follow the xy deflection unit with almost no delay, while always maintaining a **stable z-position of the focus**.

In addition, an innovative mount used for the RAYVOLUTION DRIVE allows highly accurate alignment and guiding of the lenses even under dynamic movements and enables excellent imaging performance of the lens system. Even **single mode fiber lasers or special beam shaping** like Ring mode lasers remain **nearly undisturbed**. The frictionless guidance also leads to significantly reduced wear and makes the RAYVOLUTION DRIVE technology **almost maintenance-free**.

With its high dynamics and reliability under production conditions, the RAYVOLUTION DRIVE technology is made for industrial additive production. It **ensures optimal flat-field correction even at high scanning speeds** throughout the entire up to 900 x 900 mm<sup>2</sup> processing field. In addition, the RAYVOLUTION DRIVE enables **highly dynamic scanning strategies such as hatching with a constant focus position**, making the AM-MODULE III the ideal solution for precise and highly dynamic AM applications.

## SCANFIELD CALIBRATOR

## HIGH-PRECISION CALIBRATION OF MULTI-HEAD SYSTEMS

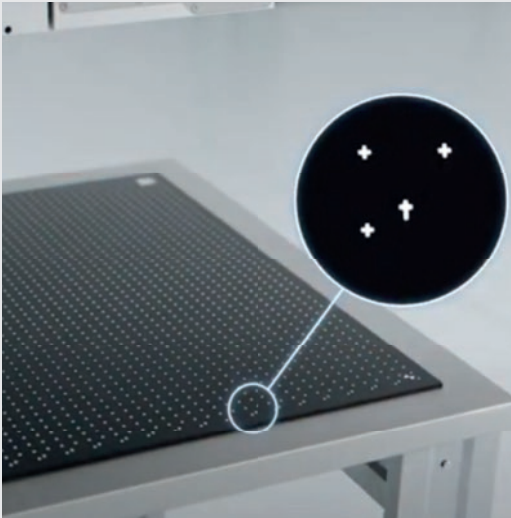

Calibration of the overlap area of an AM machine made of four AM-MODULE III

A **precisely calibrated processing field** is crucial for the part quality of an AM machine. Poor calibrations lead to measurement inaccuracies, geometric deformations and misalignments that can quickly render the build parts useless, especially in aerospace and medical applications. In addition, **accurate and regular calibration** ensures reproducibility across different batches, which is important in a serial production. But the **calibration of AM machines and especially multi-head systems** is complex and time-consuming.

In order to assist the user with this task, the RAYLASE SCAN-FIELD-CALIBRATOR was introduced. It fully automatically measures the processing field with typically **49 x49 measuring points** and uses them to create optimized correction files for the deflection unit. The SFC offers an **average correction accuracy in the process field of  $\pm 15 \mu\text{m}$ , comparable to a coordinate measuring machine**. The complete calibration process is carried out via a user interface with just a few clicks, preventing media discontinuity and thus reducing potential sources of error. As a result, even the **regular calibration of multi-head systems in AM production** becomes a convenient routine.

## RAYSPECTOR

## PROCESS OPTIMIZATION WITH PYROMETER &amp; HIGHSPEED CAMERA

„Data is the new gold.“ It allows process control and optimization, quality control and documentation. Therefore, it is important to collect and use data during the manufacturing process. But for **process monitoring** to work smoothly, the scanning system and components must be optimally matched. On-axis data in particular can only be meaningfully interpreted if they are merged with the position values of the mirrors afterwards. The AM-MODULE III with its digital electronics offer optimal pre-conditions for this, as for example the **position values of the galvos can be read back together with the data of a pyrometer** via the SP-ICE-3 card and conveniently combined to **form a heat map**.

Also for an **observation of the laser process with high-speed cameras**, the combination of RAYSPECTOR and AM-MODULE III offers the suitable solution. With the RAYVOLUTION DRIVE technology, the imaging optics of the camera in the RAYSPECTOR can be moved highly dynamically and synchronously with the scan mirrors, thus enabling an **in focus observation of the laser process**. These analyses are particularly interesting **for process optimization**, as they help the user to recognize the dynamics of the melt pool and possible irregularities and to adjust the process parameters accordingly.



Highspeed camera images of a melting pool with donut and Gaussian caustics

## OTHER SUITABLE ACCESSORIES

## SP-ICE 3

## CONTROL CARD WITH FEEDBACK FUNCTION

The central control unit for runtime-critical process steps. Enables synchronous control of the deflection unit, laser and peripherals and also allows scanner and sensor signals to be read out and connected comfortably.

## THIS MAKES RAYLASE SPECIAL

Technical specifications are important and often decisive. But at RAYLASE, we believe that there is more to it than pure technology that matters. For this reason, we are your partner for reliable and successful laser processes and offer more than just technical components.



### Systems view instead of components

Modern production systems for laser processing are usually designed specifically for one process step and are highly optimized. It is therefore important to consider the interplay with the other machine components when selecting suitable beam deflection units. At RAYLASE, we therefore always have the entire solution in mind and offer our customers assistance in putting together suitable components.



### Broad application knowledge

For many processes, the beam deflection unit is a decisive component. Often it determines whether the desired spot parameters and processing speeds can be implemented on the component. To identify the optimal solution here, we support our customers in selecting the right beam delivery components and sensor technology, and perform simulations of the laser processes developed by our customers. In addition, we provide support in the parameterization of the laser and deflection unit or software functionality through the experts at our Technical Competence Center TCC.



### On-site support for implementation and service

Our customers are the experts for their application – we are the experts for our beam deflection units. That's why we support our customers during the commissioning of our products – if necessary also directly on site. In this way, we at RAYLASE ensure that our system is optimally adjusted and permanently delivers what it is capable of.



### Education & training on the system

Modern laser deflection units are complex systems. Therefore, it is important to have a good knowledge of their characteristics. Because only when users know how the various parameters interact the optimum process becomes possible. For this reason, we at RAYLASE put a high priority on training for our products. In addition, we also offer our customers on-site training directly on the system, if required, to enable users to operate the system independently.



### The POWER OF WE

Together you achieve more. At RAYLASE, we are convinced about this. That's why we place great value on cooperation in a spirit of partnership and open communication at equal level – from expert to expert. Because only when we jointly find the best solution and successfully integrate it into the machine, everyone involved benefits in the end – our customers, us and also the end users.

## GENERAL SPECIFICATIONS

Energieversorgung	Voltage [V]	+48	
	Current (BASE-Module) (RMS) [A]	6	
	Current (max.) [A]	10	
	Ripple/Noise @ 20 MHz bandwidth [mV pp]	max. 200	
Ambient temperature [°C]	+15 to +40		
Storage temperature [°C]	-10 to +60		
Humidity non-condensing [%]	≤ 80		
IP-Code	64		
Interface signal	Digital	RL3-100 protocol, 20 Bit	
		Standard	HPS*
Typical deflection [rad] <sup>1</sup>		±0.393 (±22°) or ±0.325 (±18.6°)	±0.393 (±22°) or ±0.325 (±18.6°)
Resolution RL3-100 20 Bit [μrad]		0.76	0.76
Repeatability (RMS) [μrad]		< 2	< 0.4
Position noise (RMS) [μrad]		< 3.2	< 1.0
Temperature drift	Max. Gain drift [ppm/K] <sup>2</sup>	15	8
	Max. Offset drift [μrad/K] <sup>2</sup>	10	15
Long-term drift 8 h without water temperature control [μrad] <sup>2</sup>		< 60	< 50
Long-term drift 8 h with water temperature control [μrad] <sup>3</sup>		< 40	< 30

<sup>1</sup> The deflection ± 18.6° or ± 22° can be selected using the correction files supplied. <sup>2</sup> Angles optical. Drift per axis, after 30 min warm-up, at constant ambient temperature and process stress. <sup>3</sup> After 30 min warm-up, under varying process loads, with water temperature control set for ≥ 2 l/min and 22°C water temperature. \* High Performance System

## APERTURE DEPENDENT SPECIFICATIONS – MECHANICAL DATA

Deflection unit	SUPERSCAN IV / V -30 Kit		
Laser fiber socket	QBH		
Weight [kg]	approx. 18		
Dimensions (L x W x H) [mm] <sup>1</sup>	288 x 140 x 400		
Weight RAYSPECTOR [kg]	approx. 6		
Dimensions RAYSPECTOR (L x W x H) [mm]	274 x 122 x 224		
Total dimensions (L x W x H) [mm]	562 x 140 x 400		
		Typ. beam divergence	max. beam divergence
Typical collimator focal lengths available <sup>2</sup>		1/e <sup>2</sup> full angle [mrad]	1/e <sup>2</sup> full angle [mrad]
f = 63 mm		136	150
f = 85 mm		100	110
f = 50 mm	Fiber core <sup>3</sup>	115	125
for Multi-Core Laser	Fiber ring <sup>3</sup>	170	200

<sup>1</sup> Length without laser-specific collimator <sup>2</sup> Optical sets optimized for maximum beam divergence

<sup>3</sup> Measured with 2<sup>nd</sup> moment method

## TYPE DEPENDENT SPECIFICATIONS – TUNING

Tuning	Description
Hatching Tuning (H)	Optimized tuning for high precision beam deflection and fastest beam direction change during hatching

## TYPE DEPENDENT SPECIFICATIONS – DYNAMIC DATA

	Standard	High Performance
Deflection unit	SUPERSCAN IV-30 Kit	SUPERSCAN V-30 Kit
Tuning	H	H
Processing speed [rad/s]	30	30
Positioning speed [rad/s] <sup>1</sup>	30	30
Tracking error deflection unit [ms]	0.23 <sup>2</sup>	0.25 <sup>3</sup>
Step response time at 1% of full scale [ms] <sup>4</sup>	0.70	0.66
Acceleration time approx. [ms]	0.42	0.43
Tracking error focusing unit [ms] <sup>5</sup>	0.4–0.9	0.4–0.9
Speed of moving lens [mm/s]	900	900
Magnification factor spot diameter	1..2	1..2

<sup>1</sup> See "Calculation of speed". <sup>2</sup> Calculation acceleration time approx. 1.8 x tracking error. <sup>3</sup> Calculation acceleration time approx. 1.7 x tracking error.  
<sup>4</sup> Settling to 1/5,000 of full scale. <sup>5</sup> Tuning application dependent

## Calculation of maximum speed in field:

1 rad/s @ ± 0.393 rad deflection (± 22°) ± 0.12 m/s for 100 mm working field size.

Example: AM-MODULE NEXT GEN with working field size 400 mm x 400 mm ( field factor = 4),

Positioning speed 30 rad/s: => 30 x 0.12 m/s x 4 = 14.4 m/s

## Options:

The AM-MODULE III offers the possibility of water temperature control (W) of the electronic components and galvanometer scanners. Air cooling (A) is recommended and required for laser powers > 2 kW

This ensures constant working conditions and excellent long-term stability and guarantees reliable operation of high-power laser applications.

The AM-MODULE III can also be operated without water cooling. Without water cooling, drift values may increase.

## AIR COOLING

Specifications	
Compressed air <sup>1</sup>	Clean air free of water and oil
Flow rate	40 l/min, at > 2 kW laser power mandatory

<sup>1</sup> ISO 8573-1:2010 [1:4:0(0,005)]

## WATER TEMPERATURE CONTROL

Specifications	
Cooling water <sup>1</sup>	Clean tap water with additives
Water hardness [ppm]	< 10
ph value	7 – 8.6
Bacterial content [cfu/ml]	< 1,000
Recommended cooling temperature [°C]	22 – 28
Temperature stability [K]	± 1
Max. water pressure at deflection unity [bar]	< 3
Min. water flow [l/min] and pressure drop [bar]	2 / 0.4
Tube outer diameter [mm]	8

<sup>1</sup> **Caution:** When using cooling water including deionised water, suitable additives must be used to prevent the growth of algae and protect the aluminium parts against corrosion.

**Additive recommendations (Please consult your additive supplier for dosage information):**

Standard industrial applications: Products of company NALCO, e.g. CCL105 (Premix) or TRAC105A\_B (Additive)

Food & beverage, packaging applications: Polypropylene glycol of company Dow Chemical, e.g. DOWCAL N

## CONFIGURATION EXAMPLES – AM-MODULE III

	working distance	Ø spot @ M <sup>2</sup> =1 @ zoom 1x [µm]	zoom max.	processing field [mm]	Joint processing field in a quadruple layout [mm] <sup>1</sup>
<b>Y max 18.6° (opt)</b>	318	44	1.9x	250x250	60x60
	442	57	2.0x	333x333	143x143
	566	70	2.1x	417x417	227x227
	875	103	2.2x	625x625	435x435
	1,061	123	2.2x	750x750	560x560
	working distance	Ø spot @ M <sup>2</sup> =1 @ zoom 1x [µm]	zoom max.	processing field [mm]	Joint processing field in a quadruple layout [mm] <sup>1</sup>
<b>Y max 22° (opt)</b>	318	44	1.8x	300x300	110x110
	442	57	1.9x	400x400	210x210
	566	70	2.0x	500x500	310x310
	875	103	2.2x	750x750	560x560
	1,061	123	2.2x	900x900	710x710

<sup>1</sup> With 100% field overlap.

**Note:** The AM-MODULE III is delivered with 2 correction files. Loading the correction file determines the deflection angle and influences the processing field size, working distance and spot size.

## OPTICS SPECIFICATIONS

<b>Laser</b>	<b>Fiber Laser infrared 1,060 nm – 1,090 nm</b>
<b>Coating / Wavelength [nm]</b>	SC 1,060 – 1,090 + AL
<b>Max. laser power, cw [W]</b>	2,000 single mode / 4,000 multi mode

SC = silicon carbide

## PROCESS MONITORING

	<b>AM-MODULE III</b>
<b>Process light output wavelengths [nm]</b>	400 – 900 + 1,300 – 2,100

Every AM-MODULE III is equipped with a dust proof, optical output for process light radiation. Both very short wavelengths below the laser wavelength and long-wave thermal radiation are transferred externally. This means that various sensors can be connected, e.g. cameras for position detection, weld quality monitoring and pyrometers. The RAYSPECTOR monitoring module can be adapted to the AM-MODULE III. This enables high-speed camera recordings for process development, for example.

The AM-MODULE III comprises patented technology: U.S. Patent No. 11,402,626 – All trademarks are registered trademarks of their owners.

**Headquarters:**  
**RAYLASE GmbH**  
 Wessling, Germany  
 ☎ +49 8153 9999 699  
 ✉ info@raylase.de

**Subsidiary China:**  
**RAYLASE Laser Technology (Shenzhen) Co.**  
 Shenzhen, China  
 ☎ +86 755 28 24 8533  
 ✉ info@raylase.cn

**Subsidiary USA:**  
**RAYLASE Laser Technology Inc.**  
 Newburyport, MA, USA  
 ☎ +1 978 255 1672  
 ✉ info@raylase.com